

Breeze

Breeze brings together functionality, acoustics, and aesthetics in a single, elegant design. Inspired by natural, rounded forms, the spherical shade houses a high-quality LED panel that emits soft, diffused light through its slats creating a warm and inviting atmosphere.

The organically shaped slats not only enhance acoustic performance but also contribute to smooth light diffusion.

Available in two sizes and a variety of PET Felt colors, Breeze offers both design flexibility and technical performance. The LED panel delivers consistent, even illumination, with multiple options in color temperature and dimming to match different environments and moods.

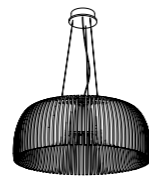

Breeze 800



Breeze 1000

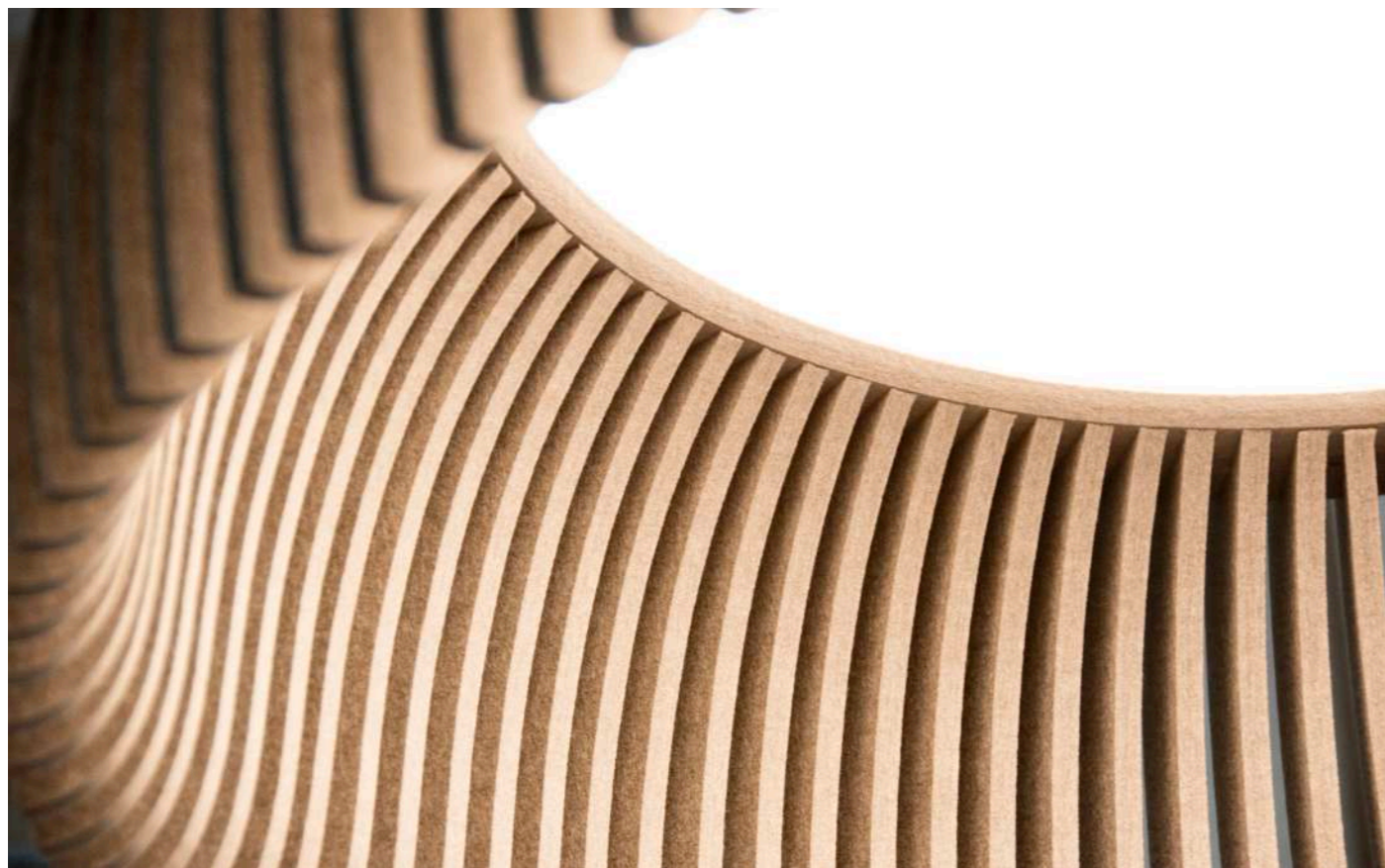



Glueless assembly

Material:

PET Felt (polyethylene terephthalate)
Fireclass: EN13501-1 Class B
Produced in The Netherlands

Fixture:

1,3m transparent cable
3 metal wires with adjustable griplock
Black ceiling cap

Lighting properties:

Integrated LED
40W | 4202lm



Dimmable
Trailing edge (RC) | DALI



3000K | 4000K



IP20

Acoustic properties:

1,75 m² of acoustic absorption
material of α_w 0,45

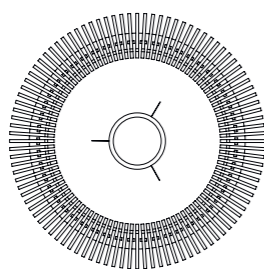
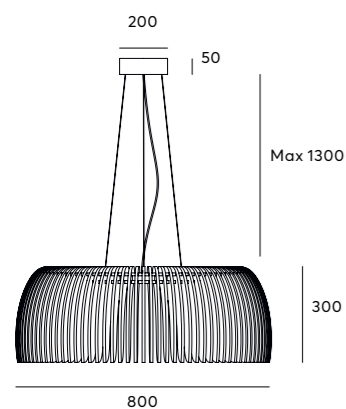

Diffusion due to the 'lamella' design

Dimensions:**Total weight gross | net:**

11,3 | 10,2kg

Parcel size Flat pack product*

730x730x150mm

Mounting:

* Products for export will be shipped Flat packed. Needs to be assembled by customer on location.
Within The Netherlands, shipped by Luminaire's own transport logistics and with additional charge;
On request, The product can be delivered assembled.

Colors:**Light source specifications:**

Based on calculations of Breeze 800 in colour 26_Ocean | 3000K | Trailing edge

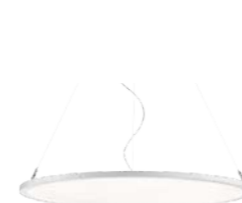

LED power:	40W
Connection voltage:	220-240V AC
Luminous Flux: 3000K/4000K	4202lm / 4421lm
Life time:	L80/B50 44.000h
Driver:	Included Integrated
Control/Dimmable:	Trailing Edge DALI
Power factor: 3000K/4000K	105lm/W 110lm/W
Optics Beam of light:	prismatic diffuser 90°
CCT Color temperature:	3000K 4000K
CRI:	Ra >90
UGR:	<19
Operating temperature:	-20 ~ +45

Photometrics:

Lumen intensity distribution

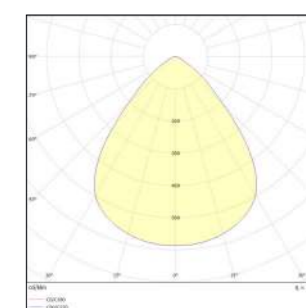
**Acoustic specifications:**

The acoustic design principle.

Breeze is designed to capture sound directly at its source — in spaces like meeting rooms or over meeting tables. Its structure, featuring acoustic lamellae, effectively absorbs and diffuses sound waves for improved acoustic comfort.

The LED element, will reflect the soundwaves

Calculated acoustic surface area: 1,75 m²

α_w (ISO 11654) = 0,45

SAA (ASTM - C423) = 0,45

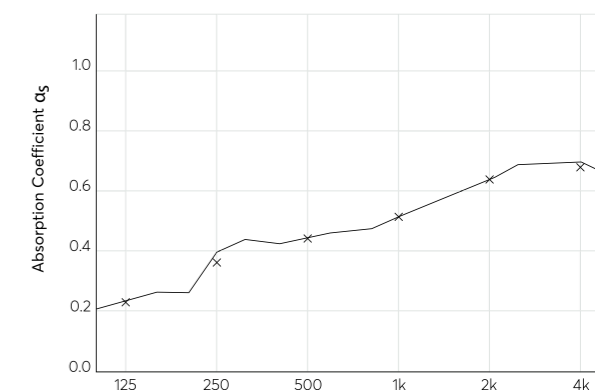
Measurement of 9mm free hanging PET Felt
sound absorption calculation in a reverberation room

	Frequency (Hz)					
	125	250	500	1k	2k	4k
1/3 oct.	0.16	0.21	0.38	0.43	0.55	0.65
	0.19	0.35	0.40	0.47	0.59	0.65
	0.21	0.39	0.42	0.51	0.64	0.61
1/1 oct.	0.19	0.32	0.40	0.47	0.59	0.64

Breeze 1000

**Material:**

PET Felt (polyethylene terephthalate)
Fireclass: EN13501-1 Class B
Produced in The Netherlands

Fixture:

5m transparent cable
3 metal wires with adjustable griplock
Black ceiling cap

Lighting properties:

Integrated LED
62W | 5883lm



Dimmable
DALI



3000K | 4000K



IP20

Acoustic properties:

3,45 m² of acoustic absorption
material of aw 0,45

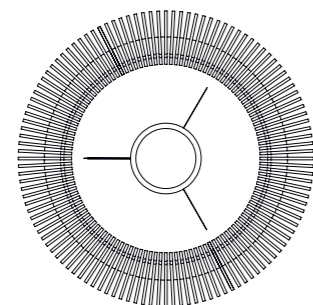
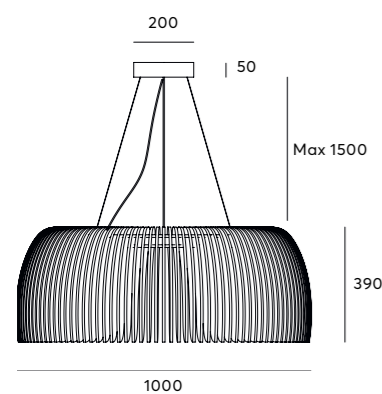

Diffusion due to the 'lamella' design

Dimensions:**Total weight gross | net:**

14,6 | 12,8kg

Parcel size Flat pack product*

930x880x170mm

Mounting:

* Products for export will be shipped Flat packed. Needs to be assembled by customer on location.
Within The Netherlands, shipped by Luminaire's own transport logistics and with additional charge;
On request, The product can be delivered assembled.

Colors:**Light source specifications:**

Based on calculations of Breeze 800 in colour 26_Ocean | 3000K | Trailing edge



LED power:	62W
Connection voltage:	220-240V AC
Luminous Flux:	5883lm
Direct / Indirect lighting:	60% / 40%
Life time:	L80/B20 50.000h
Driver:	Included Integrated
Control/Dimmable:	DALI
Power factor:	95lm/W
Optics Beam of light:	Acrylic prismatic Lens 90°
CCT Color temperature:	3000K 4000K
CRI:	Ra >80
UGR:	<19
Operating temperature:	-20 ~ +45

Photometrics:

Lumen intensity distribution

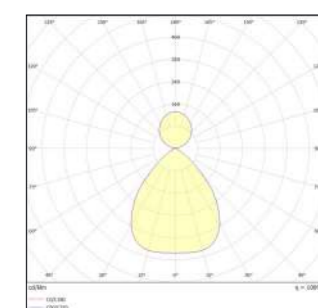
**Acoustic specifications:**

The acoustic design principle.

Breeze is designed to capture sound directly at its source — in spaces like meeting rooms or over meeting tables. Its structure, featuring acoustic lamellae, effectively absorbs and diffuses sound waves for improved acoustic comfort.

The LED element, will reflect the soundwaves

Calculated acoustic surface area: 3,45 m²

aw (ISO 11654) = 0,45

SAA (ASTM - C423) = 0,45

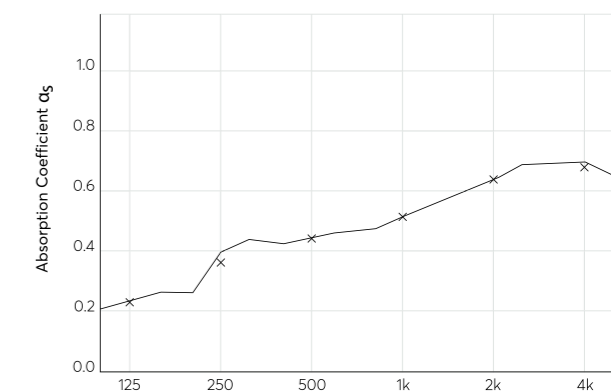
Measurement of 9mm free hanging PET Felt
sound absorption calculation in a reverberation room

	Frequency (Hz)					
	125	250	500	1k	2k	4k
1/3 oct.	0.16	0.21	0.38	0.43	0.55	0.65
	0.19	0.35	0.40	0.47	0.59	0.65
	0.21	0.39	0.42	0.51	0.64	0.61
1/1 oct.	0.19	0.32	0.40	0.47	0.59	0.64